

SELF-PRIMING MACERATOR PUMP WITH RUN-DRY PROTECTION

FEATURES

- Pump:** Self-Priming Flexible Impeller with Stainless Steel Wearplate
- Impeller:** Jabsco Nitrile compound
- Macerator:** Stainless Steel Cutter reduces particle size to 1/8" (3mm) maximum
- Seal:** Lip Type
- Ports:** Inlet - 1-1/2" (38mm) Hose Barb and 1-1/2" N.P.T. (Male)
Outlet - 1" (19mm) Hose Barb
- Motor:** Permanent Magnet Type, Fully Enclosed, with Stainless Steel Shaft Includes Run-Dry Protection Device that shuts-off pump. Powder coated housing with sealed end-bells and bearings.
Complies with USCG Regulation 183.410 and ISO 8846 MARINE for Ignition Protection.
- Weight:** 5 lb (2.3 kg) Approx.

VARIATIONS AVAILABLE

MODEL NO.	DESCRIPTION
18590-1000	12 Volt
18590-1090	12 Volt EMC 
18590-1001	24 Volt
18590-1091	24 Volt EMC 

APPLICATION

The JABSCO 18590 series dc macerator pump unit is the ideal solution for emptying marine holding tanks when not in a discharge restricted area. The JABSCO macerator is self-priming to a five foot lift when impeller is wet, four foot when dry, and may be mounted in any convenient point in the waste discharge system. The macerator section grinds waste down to a particle size of 1/8" (3mm) maximum so it can easily be pumped through a 1" (19mm) ID discharge hose. The pump section is self-priming, permitting the unit to be mounted above the tank in a convenient location. (For optimal efficiency, locate pump as close to holding tank as possible.)

The macerator has an approximate flow rate of 12 GPM (45 LPM) and will empty a typical 30 gallon (115 litre) holding tank in less than 3 minutes.

The 18590 series waste pump will macerate and pump all waste and tissue normally found in marine and recreational vehicle waste systems.

**EXCLUSIVE
RUN-DRY PROTECTION
PLUS TRIPLE SEALED
MOTOR HOUSING**

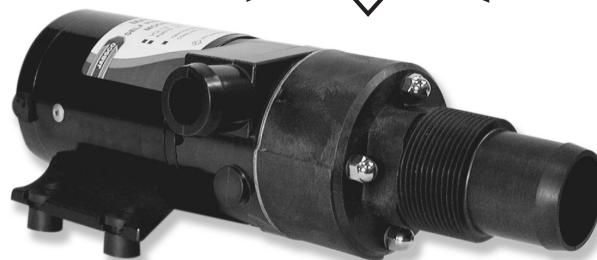

Model 18590-Series

The pumps should be used in accordance with EPA, USCG Marine Sanitation Regulations, and any regional or local ordinances.

The Jabsco Macerator is equipped with an exclusive (patent pending) Run-Dry Protection Device that shuts-off the pump to protect the flexible impeller from serious damage. The Run-Dry Protection Device can be reset by interrupting power to the pump (switching it off). The device will automatically be reactivated the next time the pump is switched on. While this unique feature protects the impeller from catastrophic damage, the impeller life will be maximized if the pump is shut-off just moments after the tank is empty. Repeated reliance on the Run-Dry Protection Device to shut-off the pump will shorten impeller life, which eventually will lessen the pump's ability to self-prime.

The macerator should be controlled by a switch that is positioned close enough to the pump so it can be heard while operating. When the tank is empty there will be a change in pump noise (louder, higher frequency) at which time the macerator should immediately be switched off.

The macerator pump unit has been designed to handle waste, toilet tissue, and facial tissue. It will also handle solids such as cigarettes, cigars and chunks of soft fruits or vegetables less than 1" size. It will not pump solid objects like fruit pits, rags, wet strength kitchen towels, tampons or sanitary napkins.

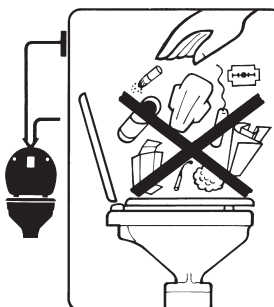

The holding tank and pump should be flushed with several gallons of water after each pumpout. Make sure the battery is fully charged. The dc motor is suitable only for intermittent duty and should not be run for more than 15 minutes continuously. At maximum flow

of 12 GPM (45 LPM) the macerator can empty a 180 gallon (680 liter) holding tank in a single operation.

After long periods of nonuse, the flexible impeller may stick to the pump body preventing the macerator pump from turning freely. If this occurs, the impeller can be broken free by removing the rubber cap on the shaft at the rear end of the motor, inserting a screwdriver in the slot and rotating the shaft clockwise a quarter turn or more. When impeller is broken free, reinstall the plastic cap on the motor shaft.

MOTOR ILLUSTRATION

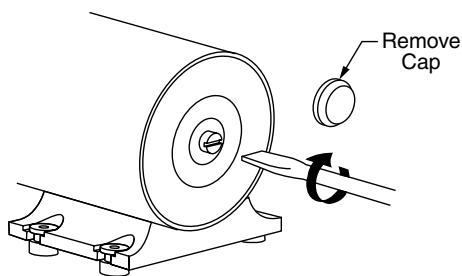

HEAD CAPACITY TABLE[†]

Head Ft	Metres	GPM	Litres	AMPS	
				12 Volt	24 Volt
0	0	12.5	47	14.0	7.6
5	1.5	11.5	44	14.5	7.8
10	3	10.5	40	15.0	8.1
15	4.5	9.0	34	16.0	8.6
20	6	7.5	28	16.5	8.9

[†] Flow rates and amperage will vary slightly depending on pump loading (sanitation system design).

INSTALLATION INSTRUCTIONS

Locating the Pump: The JABSCO macerator is self-priming to a five foot lift when impeller is wet, four foot when dry, and may be mounted in any convenient point in the waste discharge system. It may be mounted in any position or angle without affecting performance. If mounted vertically the motor should be above the pumphead. Use the rubber grommets provided to absorb vibration. Do not over tighten mounting screws. For optimal performance, mount the pump as close to tank as possible.

Plumbing Connections: Use 1-1/2" (38mm) ID, noncollapsible waste type suction hose. Slip the hose over the inlet hose barb and secure it with two stainless steel hose clamps.

The macerator may also be screwed directly into a 1-1/2" N.P.T. tank flange or female pipe fitting. If attaching the inlet port to a pipe fitting it may require removing the hose barb portion of the port with a hack-saw. If this is necessary, cut across the hose barb portion of the port about 1/8" (3mm) away from the end of the pipe threads. Wrap port threads with a couple wraps of Teflon* tape and screw the pump assembly into the pipe fitting. Tighten hand tight, do not over tighten.

NOTICE: An air leak anywhere in the suction side of the plumbing system can cause extended dry running which will cause pump to shut-off after about 20 seconds of run time.

All suction connections must be airtight and free of sharp

bends or restrictions. If a waste deck fitting is installed for dockside pump-out and connected to the suction hose of the macerator by means of a tee fitting (without a y-valve), it too must be airtight to ensure proper priming. Make certain there are no air leaks around the deck plate cap or hose tail. Use minimum 1" (19mm) ID hose for discharge and connect to thru-hull fitting located approximately 4-6 inches above waterline.

NOTICE: The discharge thru-hull may be positioned below the waterline only if the discharge hose has a vented loop fitting installed at least 8" above the waterline at all angles of heel or trim. Consult with a qualified marine plumber.

* Teflon is a registered trademark of E.I. DuPont de Nemours and Company.

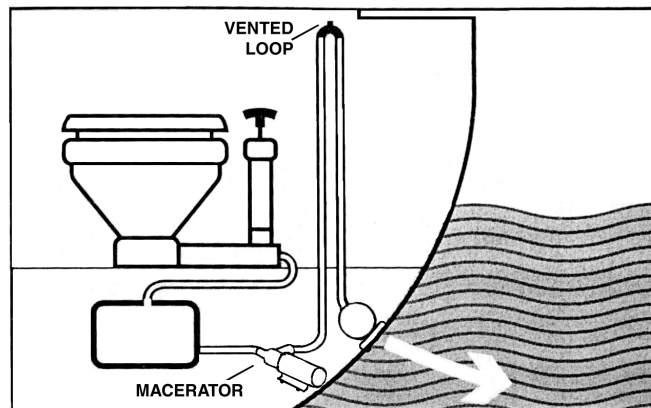

WIRING

NOTICE: Correct motor polarity (orange to positive, black to negative) is important. Reverse polarity can damage motor and void warranty.

Full voltage at the motor is required to properly operate the macerator. It must be wired in a circuit independent of all other accessories.

Use stranded copper wire of the correct size (determined from the electrical specifications chart) to connect the macerator to the power source. Undersized wire will cause a reduction of voltage that may cause the pump to seize or damage the motor. An appropriate size fuse or equivalent circuit breaker (determined from electrical specifications chart) must be installed in the positive power lead within seven inches of the power source. Alternatively the macerator may be wired to a properly installed over-current protecting electrical distribution panel. Connect the positive lead to a heavy-duty switch (see required switch amperage rating in electrical specifications chart) positioned close enough to the macerator so the operator can hear the macerator while it is running. Continue the positive lead from the switch to the macerator and connect it to the orange (positive) motor lead. Connect the black (negative) motor lead to the negative side of the battery or grounded buss bar.

ELECTRICAL SPECIFICATIONS

VOLTAGE	AMP DRAW	FUSE / SWITCH SIZE / RATING	WIRE SIZE PER FEET OF RUN*				
			0'-10'	10'-15'	15'-25'	25'-40'	40'-60'
12 Vdc	16	20	#12 (4)	#10 (6)	#10 (6)	#8 (10)	#6 (16)
24 Vdc	8	15	#16 (1.5)	#14 (2.5)	#12 (4)	#10 (6)	#10 (6)

* Length of run is total length of the circuit from the power source to product and back to ground.

EXPLODED VIEW

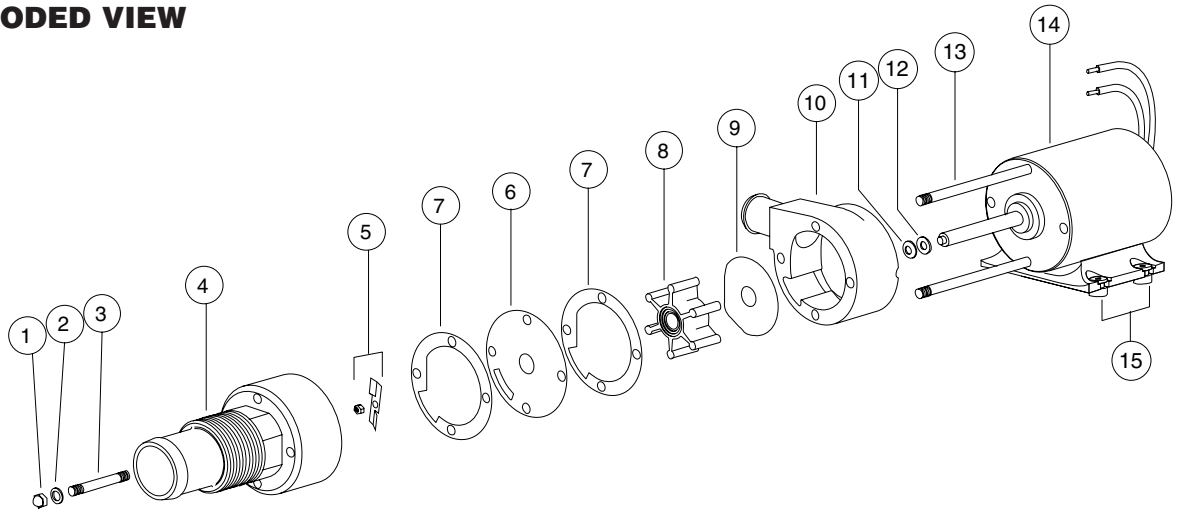

PARTS LIST

Key	Description	Qty.	Part Number
1	Acorn Nut	4	91085-0340
2	Fiber Washer*	4	91613-0140
3	Stud*	2	17288-0010
4	Macerator Housing	1	18594-1000
5	Chopper Plate with Locknut	1	37056-1000
6	Wearplate, Large	1	18597-1000
7	Gaskets (2 each per kit)*	1	18596-1000
8	Impeller*	1	6303-0003
9	Wearplate, Small	1	12316-1002
10	Body*	1	18593-1000
11	Seal*	1	1040-0000
12	Slinger	1	6342-0000
13	Stud	2	17288-0000
14	Motor 12 Volt	1	17246-0000
	Motor 24 Volt	1	17246-0001
15	Grommets (Set of 4)	1	92900-0120
	Service Kit	1	18598-1000

*These parts are supplied in 18598-1000 Service Kit.

DISASSEMBLY

Notice: Before performing any service, disconnect the electrical power to the macerator and take precaution to ensure that it is not restored until service is complete.

Remove the four acorn nuts (Key 1) and fiber washers (Key 2) from the pump studs (Key 3). Slide the macerator housing (Key 4) off the studs. Insert a thin bladed 9/32" (7mm) ignition wrench behind the chopper plate (Key 5) and onto the flat of the motor shaft to prevent it from turning. Unscrew (counter-clockwise) the locknut on the end of the motor shaft and remove the stainless steel chopper blade.^{††} On new model macerators the shaft can be prevented from turning by inserting a screwdriver in the slot of the motor shaft extending from the motor's rear end bell. Remove the pump wearplate (Key 6) and two paper gaskets (Key 7). Now slide the pump body (Key 10) with impeller (Key 8), small wearplate (Key 9), two studs and shaft seal as an assembly off the motor shaft and remaining two mounting studs. Remove the starlock retaining washer on the seal and push the seal out of the seal bore.

Notice: If reconditioning pump with a service kit (Part No. 18598-1000), it is not necessary to remove the seal because the new seal is pre-installed in the new body. It is also generally not necessary to remove the slinger or brass studs screwed into the motor end bell.

ASSEMBLY

If installing a new seal, push it into the seal bore of the body with the lip pointing toward the impeller bore. Press the starlock washer into the seal bore with the concave side up to secure the seal in the bore. Install the two shorter studs in the two holes with threaded inserts in the new pump body and tighten finger tight. If required, screw two longer studs into the tapped holes in the motor end bell. Slide the new pump body with the shaft seal installed onto the motor shaft and two long mounting studs in the motor. Slide the small wearplate over the motor shaft and position it in the bottom of the impeller bore. Slide the new impeller onto the motor shaft and, with a counter-clockwise motion, push it into the pump impeller bore. Position one new gasket on the studs and against the pump body assuring the cut-out aligns with the inlet groove in the body. Reposition the large wearplate and second gasket on the studs and against the body; again, aligning the hole in the wearplate and gasket cut-out with the pump inlet. Position the chopper on the end of the motor shaft with drive tab aligned with flat of shaft and pointing toward the motor. Hold the shaft to prevent it from turning and secure the chopper to the shaft with the locknut. Position the macerator housing on the four studs ensuring the cut-out in the inner wall aligns with pump body inlet port and hole in the wearplate. Position a new fiber washer on each of the studs and secure the macerator housing in place with the four acorn nuts.

^{††} On pumps manufactured prior to April of 1998, position a screwdriver between the prongs of the chopper and unscrew it (counter-clockwise) to remove it and its lock washer from the motor shaft.

DIMENSIONAL DRAWING

Inches (Millimeters)

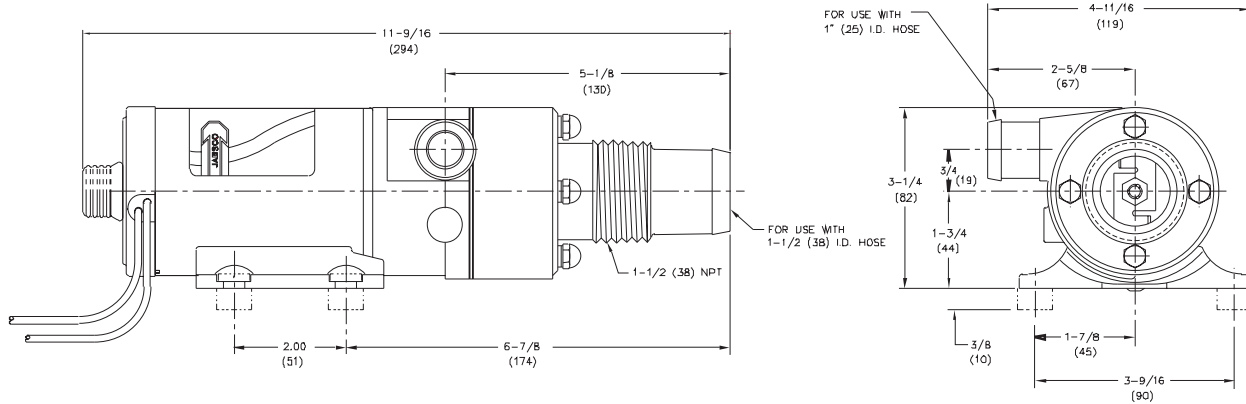

TROUBLESHOOTING

PUMP DOES NOT START:

Impeller bound-up - Insert screwdriver in slot of shaft at motor's rear end bell and rotate clockwise.

No electrical power to pump or low voltage - With a voltage tester, check power to pump. The pump must have full voltage *checked while pump is running*. If it hasn't started, see wire size recommendations and check for poor or corroded electrical connections.

PUMP RUNS BUT DOES NOT PUMP:

Lack of priming - Check all plumbing connections to ensure they are *airtight*. If a waste deck plate is connected to pump suction hose by a "Tee" fitting, the deck plate must also be *airtight*.

Worn impeller* - Replace flexible impeller.

*A worn impeller may be a likely cause if the Run-Dry Protection Device has often been allowed to shut-off the pump.

Jabsco



ITT Industries
Engineered for life

THE PRODUCTS DESCRIBED HEREIN ARE SUBJECT TO THE JABSCO ONE YEAR LIMITED WARRANTY, WHICH IS AVAILABLE FOR YOUR INSPECTION UPON REQUEST.

U.S.A.
Jabsco
Cape Ann Industrial Park
Gloucester, MA 01930
Tel: 978.281.0440
Fax: 978.283.2619

UNITED KINGDOM
Jabsco
Bingley Road, Hoddesdon
Hertfordshire EN11 OBU
Tel: +44 (0) 1992 450145
Fax: +44 (0) 1992 467132

CANADA
Fluid Products Canada
55 Royal Road
Guelph, Ontario N1H 1T1
Tel: (519) 821.1900
Fax: (519) 821.2569

JAPAN
NHK Jabsco Company Ltd.
3-21-10, Shin-Yokohama
Kohoku-Ku, Yokohama, 222
Tel: 045.475.8906
Fax: 045.475.8908

GERMANY
Jabsco GmbH
Oststrasse 28
22840 Norderstedt
Tel: +49-40-53 53 73 -0
Fax: +49-40-53 53 73 -11